

## INFRASOUND AND THE PARANORMAL

by STEVEN T. PARSONS

### *ABSTRACT*

Infrasound has become established within paranormal research as a causal factor in the production of subjective experiences that may be interpreted by the percipient as having a paranormal origin. This paper introduces infrasound and describes the nature of sound and infrasound, its production and measurement and interactions with structures. Human hearing and the perception of low-frequency sounds and the psycho-physiological interactions between infrasound and human percipients are discussed. This paper will consider infrasound measuring techniques and choice of a suitable sound filter weighting scale, together with a description of equipment designed by the author to permit infrasound monitoring and measuring to be undertaken at selected locations throughout the UK and Eire. The historical links between low-frequency sound and infrasound and the development of the case for infrasound in the production of anomalous experiences are examined. Following the hypothesis that a frequency of close to 19Hz was key in the production of anomalous experiences (Tandy & Lawrence, 1998), the focus of parapsychology has been towards testing this hypothesis. Studies such as 'The Haunt Project' (French et al., 2009) and pilot studies by the author have focused on this range of infrasound frequencies. This paper will argue that the original hypothesis failed to understand fully the manner in which the frequencies of infrasound standing waves are determined and will examine critically the results of The Haunt Project, suggesting that the failure of the experimenters to understand all the problems of infrasound measurement and propagation may have led to an unreliable conclusion. Finally, the paper will discuss the question of an infrasound role in the production of anomalous experiences.

### INTRODUCTION

Infrasound is generally considered to be audio-frequency energy that lies below the range of normal human hearing, typically 20Hz (Leventhall, Pelmeier & Benton, 2003). Ambient infrasound within the environment is produced by both natural and man-made sources. Natural sources include weather-related effects (e.g. wind and storms) surf and wave action, volcanic eruptions and upper atmospheric phenomena (e.g. the jet stream and meteors —cf. von Gierke & Parker, 1976; Gossard & Hooke, 1975). Man-made infrasound is associated with vehicles and aircraft, machinery and the interactions of weather with buildings and other structures (Blazier, 1981; Stubbs, 2005). Ambient infrasound levels from natural and man-made causes are variable in intensity and there have to date been a limited number of measurements of ambient environmental infrasound (e.g. Bruel & Olesen, 1973). From these few studies, however, and the author's own unpublished survey of ambient infrasound levels at more than 30 locations in the UK, it is clear that ambient infrasound is often to be found at levels of 50–80dBS in rural locations, and frequently in excess of 90 or 100dBS in suburban areas and close to industry and major transport routes. Bruel and Olesen showed that the amount of infrasound rose markedly as a result of increased weather (particularly wind)

interactions with structures, a finding that the author also noted in his own measurements. Because of its low frequencies and long wavelengths, infrasound is capable of travelling long distances with little attenuation. Consequently, much of the infrasound energy, even from sources which produce sound energy across the entire sound-frequency spectrum, will be apparent at considerable distances. The infrasound shockwave or sonic boom from Concorde travelling between London and New York has been measured at up to 75dBS in the North of Sweden (Berglund et al., 1996). The infrasound from volcanic and other seismic events can be recorded as it travels around the Earth numerous times, losing only a small percentage of its total energy on each circuit (Backteman et al., 1983). It is therefore clear that infrasound is not only present almost everywhere but it is also present at considerable amplitudes, although it is largely undetectable by normal hearing and unmeasurable by the majority of available sound-level measuring equipment. Westin (1975) noted in a review paper dealing with the effects of infrasound on man that the amounts of natural and man-made infrasound that man is subjected to are larger than is generally realised, and commented that few studies have concerned themselves with the physiological effects of moderate-to-high levels of infrasound exposure.

In the past decade, infrasound has captured the attention of investigators of the paranormal. This interest follows studies that have postulated a causal link between infrasound energy and the appearance of apparitions (e.g. Tandy & Lawrence, 1998). Although not the first to link infrasound with paranormal experiences, Tandy proposed that exposure to infrasound close to 19Hz was instrumental in the production of psycho-physiological experiences that were subjectively reported as being paranormal in their origin (Tandy & Lawrence, 1998). As a result of Tandy's research, paranormal investigators have taken a keen interest in infrasound. Tandy's suggestion was based upon existing studies carried out on behalf of the United States space programme and military weapons research (Altmann, 1999). These research programmes were set up to study the physiological and psychological effects of infrasound exposure on astronauts and military personnel. Experiments used high infrasound exposure levels (150dBS–170dBS)—much higher than would be expected to be found in homes, industry or from environmental sources.

The secrecy surrounding lethal and non-lethal acoustic weapons development and a lack of information detailing the effects of high levels of infrasound exposure have resulted in periodic dramatic and even alarmist claims being made within the media about infrasound and its effects (“The Silent Sound Menaces Drivers”, *The Daily Mirror*, 19th October 1969, p. 18; “Brain Tumours ‘caused by noise’”, *The Times*, 29th September 1973, p. 7; “The Silent Killer All Around Us”, *London Evening News*, 25th May 1974, p. 11). As a result of these distorted claims, infrasound began to develop a popular mythology and was blamed for many ailments and misfortunes for which no other explanation could be forthcoming. These have included brain tumours, cot death and road accidents (Tempest, 1971). In 1973, Lyall Watson published *Supernature: A Natural History of the Supernatural*, in which he repeated a series of claims originally made by French weapons scientist Vladimir Gavreau, including: “that in an experiment with infrasonic generators, all the windows were

broken within a half mile of the test site”, later adding that “two infrasonic generators focused on a point five miles away produce a resonance that can knock a building down as effectively as a major earthquake” (Watson, 1973). Gavreau’s original claims (Gavreau, 1966) have never been substantiated and they have been disputed by many subsequent researchers. However, these sometimes extraordinary and frequently misleading claims about the physical and physiological effects of infrasound, combined with a general lack of research into the effects of exposure both to naturally occurring and to man-made infrasound have permitted some to popularise the idea that infrasound is the cause of many paranormal experiences (Fielding & O’Keeffe, 2006).

Many field researchers have developed their own theories and explanations of a relationship between infrasound and the paranormal. Some of these, however, appear to be the work of a creative rather than a logical mind. On their internet site an established and well-known paranormal group claim that “infrasound is caused by ghosts and spirits as they use electromagnetic energy to move things or materialise, just as lightning which is moving energy creates thunder which is infrasound, this can be recorded and used to prove that spirits are present.” Another respected team of investigators claim to have recorded many infrasonic EVPs (electronic voice phenomena) using handheld digital dictation recorders, which are completely incapable of recording or measuring such infrasound. There seems to be a generally poor understanding of the original work by Tandy, and of the technical constraints in making infrasound measurements, and this has led to misunderstanding of any actual relationship between infrasound and paranormal experiences and accounts.

Therefore this paper will examine some of the physical properties of low-frequency sound and consider some of the techniques to detect and measure infrasound. Furthermore, it will consider the perception of infrasound and the psycho-physiological effects of infrasound exposure, and examine links to reports of anomalous and paranormal experiences.

#### THE PHYSICS OF SOUND

Our most common experience of sound is in air, but sound is able to travel through any solid, liquid or gaseous medium. Sound is normally produced by anything that is vibrating and causing the surrounding molecules to vibrate in sympathy with the source. These vibrations travel in the form of a wave which can be defined as a travelling disturbance consisting of coordinated vibrations that transmit energy with no net movement of matter (Ostdiek & Bord, 2000). Sound waves take the form of alternating compression and rarefaction; this is known as a longitudinal wave. In air, sound waves travelling past a fixed point cause the atmospheric pressure to vary slightly above and below the steady barometric pressure.

#### *Wavelength, Frequency and Velocity*

The distance between any two corresponding points on successive waves is termed the wavelength. Frequency refers to the number of successive waves that are emitted from the source in one second. Frequency is stated in units of Hertz (Hz), i.e. 100 wavelengths per second are expressed as 100Hz. In air, under normal conditions, sound waves travel at about 342 metres per second

(m/s). In air the velocity of sound varies slightly with the air temperature (Talbot-Smith, 1994). In materials that have a higher molecular density, sound waves will have a higher velocity. For example:–

Air (at 18°C)	342.04 m/s
Water	1480 m/s
Glass	5200 m/s
Steel	5000–5900 m/s; depending on the composition of the metal
Helium Gas	965 m/s

Wavelength, velocity and frequency are linked by a simple mathematical formula:–

$$\text{wavelength} = \frac{\text{velocity}}{\text{frequency}}$$

Using this formula we are able to determine the wavelength for any given frequency. For example, in air, for a frequency of 20Hz and a temperature of 18°C, the wavelength would be  $342.04 \div 20 = 17.10$  metres. The same formula allows the calculation of frequency, as velocity divided by wavelength, which in this case gives  $342.04 \div 17.10 = 20\text{Hz}$ .

#### *Units of Measurement Used for Sound*

Sound waves are oscillations in atmospheric pressure and their amplitudes are proportional to the change in pressure during one oscillation. There are several ways of expressing the amplitude or intensity of sound waves. However, it is commonly expressed as sound pressure. In scientific terms this is defined as the force acting on a unit of area. Thus sound pressure waves are normally given as Newtons per square metre (N/m<sup>2</sup>). More recently it has become the official practice to refer to the N/m<sup>2</sup> as the Pascal (Pa). The sound pressure variations that are detectable by a typical human ear are immense. For example, the quietest sound that can be detected has a Sound Pressure Level (SPL) of 0.00002 Pascal (Pa) and the loudest sound has an SPL of around 200Pa. In order to simplify the expression of sound pressure levels the decibel (dB) is more commonly used. This is a unit of comparison and so must be stated against a reference value to be meaningful. Formally expressed, the number of dB represents a ratio of two powers using the formula  $\text{dB} = 10 \log(\text{power ratio})$ . An SPL of 0.00002Pa is referred to as 0dB, and this is the reference value against which all comparisons of SPL are expressed.

This standard allows any sound pressure to be quoted as (x)dB above that pressure and is expressed as dB(SPL) or more often simply dBS. Thus a sound that is 10 times more powerful than the reference SPL is expressed as 10dBS, a sound 100 times more powerful is 20dBS, a sound 1,000 times more powerful is 30dBS, etc. An SPL of 140dB (200Pa), which is 100,000,000,000,000 more powerful than the reference, will cause rapid ear damage and aural pain.

#### *Sound Waves and Structures*

Sound waves are absorbed, reflected or diffracted by obstacles in their path. Absorption or reflection of a sound wave reduces the amount of energy it is able to transmit. This will reduce the loudness of subsequent sounds and will

also cause an attenuation of the distance that the sound waves can travel. For reflection of the sound waves to occur, the wavelength must be smaller than the dimensions of the reflecting object. For example, if the side of a building is 10m high and 20m long, these dimensions of the building will have an appreciable effect upon the reflection of sounds with wavelengths of less than 10m. This corresponds to frequencies of around 34Hz. Sounds above that frequency will be more easily reflected. If sound waves with a lower frequency and correspondingly longer wavelength encounter the same obstacle they will not be reflected but will instead bend around the obstacle, a process called diffraction. If the wavelength is much greater than the obstacle size then there will be marked bending around the obstacle. At infrasonic frequencies the wavelengths are considerable, and therefore very little of the infrasound wave energy is reflected. Absorption of the infrasound wave may also be significantly lower than for audible sounds. Therefore infrasound waves are able to travel greater distances from the source without significant attenuation; in air infrasound may be detectable over tens or even hundreds of kilometres and even further through liquid or solid media (Mihan House, 2005).

Acoustic pressure waves reflected and refracted by the structure of a building from infrasound sources such as machinery and vehicles, both surrounding and within it, may combine with naturally produced infrasound from wind and weather interactions upon the structure, thus creating regions within the building that have significantly higher and lower levels of infrasound. Such regions may be highly localised and dependent upon the actual acoustic wave/structural interactions. Factors that will affect the local levels of infrasound and must be considered include the dimensions, shape and construction materials of a building together with the frequency and amplitude of the infrasound. If the infrasound is produced by weather and other natural sources of infrasound these too must be acknowledged. Local infrasound levels will vary over time because of variations in the ambient infrasound sources, natural or man-made, and the resultant change in their structural interactions.

When measuring infrasound within any location, a single measuring point will rarely produce an accurate overall result for that location. When measuring human infrasonic exposure, the measurements should be made as close as possible to the position of the percipient, as a difference of just a few feet can create a significant difference of the SPL in the local infrasound levels (Para.Science, 2007).

#### HEARING AND THE PERCEPTION OF LOW-FREQUENCY SOUND

The human ear has a generally quoted frequency range from about 20Hz to around 20,000Hz. However, it has been demonstrated that acoustic stimuli with frequencies as low as 1Hz can not only be heard, but can also be described in terms of loudness (Yeowart et al., 1967).

The actual mechanisms of infrasound detection are not fully understood but it has been suggested that at very low frequencies detection does not occur through hearing in the normal sense. Rather, detection results from nonlinearities of conduction within the middle and inner ear, created as the vibrations pass through body tissues of different densities such as bone and soft tissue, which have different sound conduction properties. This generates harmonic

distortion in the higher, more easily audible, frequency range (von Gierke & Nixon, 1976). Infrasound waves may also be detected through skeletal bones, bones within the ear, resonance within organs and body cavities, and tactile senses (Job, 1993). The inability of most people to ‘hear’ infrasound means that its effects upon a person are largely unexpected and therefore more likely to be attributed to other causes, and in some instances where the percipient is in a haunted location or involved in the pursuit of ghost-hunting such effects are frequently blamed upon a paranormal agent or cause.

#### *Low-Frequency Hearing Thresholds*

Although infrasound is normally defined as audio-frequency energy that lies below the range of normal hearing, a number of studies have been conducted for the purpose of determining the lowest sound levels which are audible to the average person with normal hearing (Corso, 1958; Lydolf & Moller, 1997; Moller & Andresen, 1984; Watanabe & Moller, 1990). From these studies the average low-frequency thresholds can be established. Thus, referring to Figure 1, it can be seen that an average person might be expected to hear a sound with a frequency of 16Hz when the sound pressure exceeds 120dB (SPL) and a sound of 4Hz at a sound pressure exceeding 130dB(SPL). Simply stated, it is perfectly possible for an average person to hear infrasound provided that the amplitude is sufficiently high.

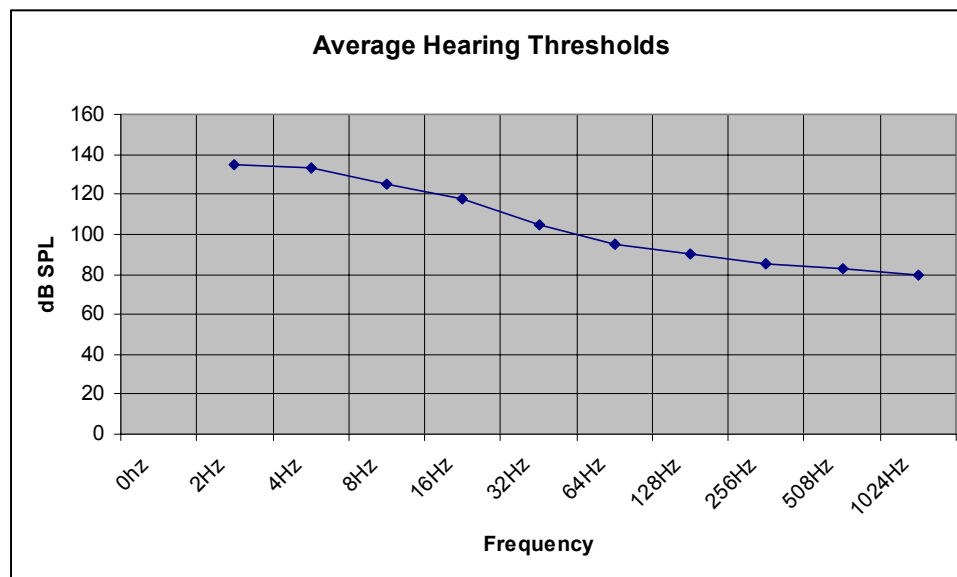

*Figure 1. Low-frequency hearing thresholds.*

#### *Individual Hearing Thresholds*

The threshold levels described are an average over groups of people. An individual’s threshold may vary considerably from these values. Frost (1987) compared two subjects over a range of frequencies from 20Hz to 120Hz. At 40Hz one individual was 15dB more sensitive than the second. Yamada

(1980) reported female thresholds to be around 3dB more sensitive than male thresholds except at the lowest frequencies, below 16Hz. It was also found that individual differences could be large. In one case, a male subject had a hearing threshold which was 15dB more sensitive than the average. Thus an individual's ability to hear sound, including infrasound, will be dependent upon his or her actual hearing threshold.

#### *Perception of Low-Frequency Sound and Infrasound*

The function of the auditory system is to perceive objects and events through the sounds they make (Masterton, 1992). The physical dimensions of sound are usually expressed in experiments using perceptual terms; the amplitude, frequency and complexity of the sound vibrations are perceived as loudness, pitch and timbre respectively.

The relationship between the acoustic signals and perception has been tested although the research has concentrated on speech and language (e.g. Lisker & Abramson, 1970). Studies looking at low frequency and infrasound have mainly been concerned with predicting loudness or annoyance and for the establishment of safe exposure limits (Challis et al., 1978; Fields, 2001). The research so far has concentrated on using very high sound pressure levels to establish safe exposure limits (e.g. Jerger et al., 1966). There is currently no comparable research that has provided data for normal exposures. Data to indicate the infrasonic sound pressure levels that might normally be expected to be found in the general environment are also unavailable.

In psychophysical terms, the perceived loudness of a pure tone grows as a power function with sound pressure (Stevens, 1975). Goldstein (1994) showed that for a low-frequency tone of 20Hz a doubling in the perceived loudness is achieved with only a 4–5dB increase in SPL for the low-frequency tone, whereas the SPL of a higher-frequency tone of 1,000Hz (1kHz) would need to be increased by 9–10dB to achieve the same perceived doubling in loudness. Pitch discrimination is also affected by low-frequency sound. At 25Hz, the ability to discriminate pitch is about three times worse than for sounds at 63Hz (Usher, 1977). The ability to determine from which direction a sound is coming, known as the 'Haas Effect', is also seriously impaired. Low frequencies can travel great distances without substantial attenuation and can easily penetrate many buildings and structures. Directionality may also be affected by the way low-frequency 'hearing' involves multiple structures within the body rather than just the ears.

The ability of an individual to perceive infrasound is also affected by the presence of other ambient sound within the audible-frequency range, i.e. above 20Hz, the audible sounds having a tendency to mask or reduce the threshold of perception of infrasound by between 6 and 12dB (Yasunao et al., 2009).

#### *Psychological and Physiological Effects of Infrasound*

A number of studies have been conducted to study the psychological and physiological effects of infrasound on individuals (e.g. Chen & Hanmin, 2004; Moller, 1984). Such studies have used a range of pure infrasound tones at high sound-pressure levels to examine the effects of infrasound exposure upon subjects. Individuals subjected to infrasound at high SPLs reported ear

pressure, headaches and tiredness, and feeling uncomfortable or 'troubled' (Moller, 1984). Karpova and colleagues (1970) reported effects on the cardiovascular and respiratory systems, including changes in heart rate, blood pressure and respiratory rate. Although the effects of infrasound exposure have been objectively demonstrated, the results obtained from these experiments have shown highly variable effects, with different individuals experiencing different responses to the infrasound exposure (Chen & Hanmin, 2004). Infrasound exposure has also been reported to include effects on the inner ear, leading to vertigo and imbalance; intolerable sensations, incapacitation, disorientation, nausea and vomiting (Hansen, 2007). Subjects exposed to infrasound at 5 Hz and 10 Hz with levels of 100 dB–135 dB reported feelings of fatigue, apathy and depression, pressure in the ears, a loss of concentration, drowsiness and vibrations of the internal organs (Karpova et al., 1970). In a study of airline pilots, Lidstrom (1978) found that long-term exposure to infrasound of 14 Hz–16 Hz at levels around 125 dB caused decreased alertness, a faster decrease in the electrical resistance of the skin and an alteration in time perception. Other researchers have reported that infrasound exposure produced sensations of apprehension, visual effects, nausea and dizziness (Stephens, 1969), depression, fatigue and headaches (Gavreau, 1968). Gavreau (1968) further observed that ordinary man-made sources of infrasound such as fans and defective air conditioners may produce similar effects.

Anecdotally, many people report adverse physiological and psychological effects which they claim result from exposure to man-made infrasound. In response to a series of articles about the possible dangers of low-frequency noise (Anon., 1977a, 1977b), *The Sunday Mirror* received over 700 letters from readers describing a wide range of adverse health and psychological effects they attributed to low-frequency sounds, including severe headaches, nausea, palpitations, dizziness, extreme fatigue, visual hallucinations, disturbed sleep, nightmares and suicidal thoughts.

From the various studies of the biological effects it would appear that the effects of exposure to infrasound may be variable. Studies carried out using animals have also reported adverse effects from exposure to infrasound.

#### MEASURING LOW-FREQUENCY SOUND AND INFRASOUND

A number of techniques are available to detect and measure low-frequency sound and infrasound. At the lowest frequencies (i.e. below 1.5 Hz) seismometers are normally used for measuring infrasound in the form of structural vibration from tectonic sources such as earthquakes and volcanoes (Garces et al., 1998) and man-made mining explosions (Hegarty et al., 1999). Micro-barometers are preferred for the detection and measurement of infrasound transmitted through the air. These devices are highly accurate and were originally developed for the detection of infrasound generated by atomic bomb tests. They have also been used for the study of meteors, thunderstorms and weather-related phenomena, mainly in the range 0.1–5 Hz (McKisic, 1997).

For higher infrasound frequencies (typically those above 5 Hz) microphone-based measuring systems are commonly employed, such as the Bruel and Kjaer Type 2209 sound-level meter. This meter employs a microphone that is sensitive to 1 Hz and can be connected to a Fast Fourier Transform (FFT)



analyser such as the Zonic AND Type 3525 to allow spectrum analysis measurements to be made. Many of these systems have been developed to allow environmental noise measurement to be made, and the measurements are weighted using electronic filtering in order to replicate as closely as possible normal thresholds of human hearing. This has led to the development of a series of filters optimised to cover a range of different environmental and acoustic conditions. The most commonly used is the 'A' filter, which is designed for general environmental monitoring. However, a major drawback of the 'A' weighting scale is that it underestimates the importance of frequencies below 100 Hz (Berglund et al., 1996). Alternative weighting filters have been developed for specialist measurement of sounds having a significant low-frequency component, these include the 'C' filter, which is recommended for artillery noise (Schomer, 1981), and the 'D' filter, which is used for aircraft noise measurement. Both of these commonly used filters are based on hand-extrapolations into the lower frequencies and are not based upon empirical low-frequency data (Goldstein, 1994). The best noise weighting for infrasound remains to be settled but Bullen, Hede and Job (1991) found that equal energy units, sometimes called Zero or 'Z' weighting, has often provided the most effective predictor for community reaction to infrasound. Such environmental monitoring systems are expensive. Additionally, there is as yet no single standard for the measurement of environmental low-frequency sound and infrasound, which can result in difficulties when trying to make comparisons between existing studies.

#### *Acoustic Research Infrasound Detector*

With the advent of powerful personal computers it is now possible to perform measurement and analysis of these low-frequency sounds using a laptop computer and suitable software. Microphones that can operate effectively down to as low as 1 Hz remain almost prohibitively expensive but it has been possible to adapt existing loudspeaker technology to construct a microphone that will respond accurately at very low frequencies. This concept has been the basis for the author's infrasound measuring system known as the Acoustic Research Infrasound Detector (ARID; Parsons & O'Keeffe, 2008). ARID used the principle that a loudspeaker is in effect a microphone operating in reverse. A pair of large-diameter loudspeakers can be modified so that they can be used as large microphones sensitive to frequencies below 1 Hz. Signal processing is then carried out using a laptop PC with adapted available FFT spectrum analysis software.

Early trials with ARID proved that the concept worked well in practice, although the first system was bulky to transport and was occasionally prone to picking up structural vibrations via the stands. The biggest drawback with the ARID system, however, was a lack of any accepted calibration standard, and whilst we had great confidence in the resultant data, it was felt that an improved system could be developed. Continued work has resulted in a new system, referred to as ARID2. This new system replaces the earlier 'loudspeaker' microphones with a pair of one-inch-diameter dual-diaphragm air-pressure transducers housed in modified microphone cases, together with an improved Analogue to Digital (D/A) converter and modified software.

The use of microphone cases means that commercial anti-vibration mounts

for the transducers can be used, thus reducing structural vibration noise affecting the measurements. Improvements to the D/A converter, fully balanced and shielded cables, and the improved software have resulted in lower instrument noise levels and therefore improved data sampling and quality. Data sampling can be obtained continuously or at any user-selected interval from 1s to 23h 59m. The biggest advantage the new system offers is that it has been possible to calibrate the data to current ANSI (1) sound measurement standards.

Environmental sound-measuring equipment is normally designed to measure the peak sound pressure level ( $L_{peak}$ ) or an equalised value ( $L_{eq}$ ) over a selected period of time. Sudden (impulse) high acoustic pressure sounds; for example, the sudden closing of a door, footsteps and wind gusts, may cause erroneously high infrasound measurements. Measurement errors can also be caused by short-duration and transient events, such as passing vehicles or the operation of machinery. In order to minimise any measuring errors resulting from such sounds, measurement of low-frequency sound should be made over a period of several minutes or more (DIN: 4560, 1997). ARID measurements are obtained over a 15-minute period, which gives an  $L_{eq}$  result that should remove measurement errors caused by impulse and transient events.

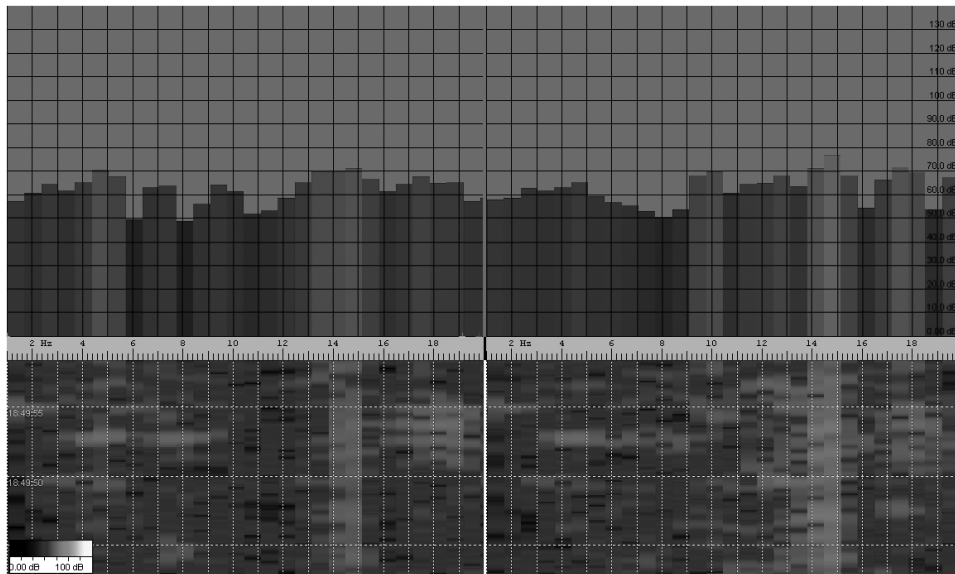

Figure 2. Typical ARID infrasound data screenshot: 0.1 Hz–20 Hz, 0 dBS–130 dBS.

## INFRASOUND AND THE PARANORMAL

### *Historical Links*

Early investigators of the paranormal recognised that vibrations were a component in some reported haunt and poltergeist cases. Harry Price, for example, included a bowl of mercury in his personal ghost-hunting kit for the detection of tremors in a room or passage (Price, 1974, p.31). Price was also aware of the ability of certain notes and sounds to cause a sympathetic vibration

in other objects. For example, he observed that in one case a particular pealing of nearby church bells caused the wires of a piano in a haunted house to vibrate in sympathy, leading to the residents reporting that ghostly music was at times being played by unseen hands (Price, 1974, p.38).

Earlier researchers of psychical reports also noted that sound vibrations played a mysterious part in the production of psychic phenomena (Fodor & Lodge, 1933). None of the early investigators directly mention infrasound, as the concept of low-frequency sounds that exist below the normal human hearing range did not gain general scientific recognition until the 1940s. Later research shows greater familiarity with infrasound. In an experiment that was set up to examine vibrations and jolts associated with poltergeist activity, Gauld and Cornell (1979) used a powerful mechanical vibrator attached to a group of abandoned houses that were scheduled for demolition. This created powerful vibrations throughout the structure of the building and could be set to vibrate at frequencies between 45Hz and 120Hz. The aim of the experiments was to test the claim that geophysical forces might be responsible for some aspects of poltergeist activity. The experiment would also have produced large amounts of infrasound within the building as the various structures were vibrated by the powerful machinery. The investigators did not report any anomalous physiological or psychological experiences during any of these experiments and confined their reporting of results to observed physical effects upon the structure.

The first direct claim of a possible causal link between infrasound exposure and reported anomalous experiences was made by Persinger (1974). He stated that:—

Infrasound, however, is an excellent candidate for at least some types of precognitive experiences. Weak infrasound energy from ambient sources could evoke vague responses and lead to reports of feelings of foreboding, depression or impending doom ahead of natural phenomena such as earthquakes or storms.

The exploration of any potential link between infrasound and paranormal experiences was not undertaken for many years, possibly because of the perceived technical difficulties in properly measuring infrasound energy within a haunt location and the lack of data relating to levels of ambient infrasound within the environment.

#### *The Development of a Case for Infrasound and the Paranormal*

Increased paranormal interest followed the publication by Tandy and Lawrence (1998) of their infrasound hypothesis. They suggested a causal role for infrasound in some instances of haunt phenomena and apparitions. The initial suggestion was based upon the observed effects on a metal sword blade and the anecdotal reports of paranormal experiences within the same location. The source of the infrasound was traced by trial and error to a defective fan within the haunted workplace. The actual frequency and amplitude of the infrasound were never directly measured but they were estimated from the authors' personal experiences, mathematical calculations and the observation of the effects (Tandy & Lawrence, 1998). The authors also noted similarities in psycho-physiological effects reported by workers exposed to low-frequency fan noise originally reported by Tempest (1976). A key suggestion of this research was that infrasound at a specific frequency range (around 19Hz) was causing

eyeball vibration and leading to visual effects that might be interpreted as apparitional encounters. Tandy later conducted a series of infrasound measurements in a 14th-century cellar beneath a tourist information centre in Coventry (Tandy, 2000). In this experiment objective measurements of the ambient infrasound were made using contemporary environmental monitoring equipment. He observed that a frequency of 19Hz was present within the location, confirming his earlier observation. Tandy's infrasound hypothesis was quickly picked up by the media and the paranormal community, and seems to have been the catalyst for the claims now being made for infrasound involvement in paranormal cases.

Without exception, infrasound exposure studies carried out other than by paranormal investigators have been for the purposes of trying to establish whether there are any adverse human health or performance implications in people who are exposed to infrasound in the workplace. These studies have predominantly used pure-tone infrasound at high or very high amplitudes or long exposure periods in their experimental design. The use of pure tones in many of the infrasound exposure studies may severely restrict the applicability of their findings to real-world situations, since ambient infrasound from both natural and man-made sources is almost without exception in the form of broadband noise consisting of fundamental notes, harmonics and resonant frequencies. The findings from these studies were reviewed earlier in this paper and describe feelings of anxiety or dread, nausea, sickness and sudden onset of headaches, effects that are similar to those reported in spontaneous paranormal cases. Initially, this similarity of experience may seem impressive and should certainly not be dismissed, but a number of problems remain to be addressed. For example, Kawano, Yamaguchi and Funasaka (1991) found that long-distance truck drivers who were exposed to infrasound at around 115dB showed no statistically significant incidence of fatigue, subdued sensations or cardiovascular changes.

#### *Should Paranormal Research be Interested in 19Hz?*

Studies by those interested in the possible links between reported paranormal experiences and infrasound exposure have so far tended to focus most of their experiments on infrasound frequencies of close to 19Hz. Interest in this frequency range comes as a direct result of the papers produced by Tandy and Lawrence (1998), and Tandy (2000). The frequency was identified by a mathematical calculation (Tandy & Lawrence, 1998):—

The following day V.T. was entering a fencing competition and needed to cut a thread onto the tang of a spare foil blade so that he could attach the handle. He had all the tools necessary but it was so much easier to use the engineer's bench vice in the lab to hold the blade that he went in early to cut the thread. It was only a five-minute job, so he put the blade in the vice and went in search of a drop of oil to help things along. As he returned, the free end of the blade was frantically vibrating up and down. Combining this with his experience from the previous night, he once again felt an immediate twinge of fright. However, vibrating pieces of metal were more familiar to him than apparitions so he decided to experiment. If the foil blade was being vibrated it was receiving energy which must have been varying in intensity at a rate equal to the resonant frequency of the blade. Energy of the type just described is usually referred to as sound. There was a lot of background noise but there could also be low-

frequency sound or infrasound which V.T. could not hear. As it happens sound behaves fairly predictably in long thin tubes such as organ pipes and ex-garages joined end to end so V.T. started his experiment. He placed the foil blade in a drill vice and slid it along the floor. Interestingly the vibration got bigger until the blade was level with the desk (half way down the room); after the desk it reduced in amplitude, stopping altogether at the far end of the lab. V.T. and his colleagues were sharing their lab with a low frequency standing wave! The energy in the wave peaked in the centre of the room indicating that there was half a complete cycle. . . . Once V.T. knew this he calculated the frequency of the standing sound wave.

The mathematical calculation of the standing wave within the lab is based solely upon a single room dimension, specifically its length, given as 30ft, and a wavelength of twice the length of the room, i.e. 60ft.

Tandy used the formula given earlier to compute frequency as the velocity of sound (1139ft/sec) divided by wavelength (60ft), which equals 18.89Hz. Apparently no account was taken of the height or width of the room, the dimensions of which are not provided. In order to determine the acoustic properties of any space and accurately calculate the frequency of standing waves within the space, calculations involving all three dimensions of the space must be used.

Broadly speaking, three types of standing wave will exist inside any space (see Figures 4–6, taken from Bruel & Kjaer, 1982). The most powerful of these are Axial waves, which involve any two parallel surfaces, such as walls, or floor and ceiling. With Axial waves there are always sound-pressure maxima at the walls. In addition Tangential waves involve any two sets of parallel surfaces—all four walls, or two walls and the ceiling and floor. These are about half as strong as the Axial modes, and also give maxima at the walls. Oblique waves involve all six surfaces (four walls, the ceiling and the floor) and are about one quarter as strong as the Axial modes, and half as strong as the Tangential modes. Oblique modes, which are rarely of much relevance, also give sound pressure maxima at the walls.

It is noteworthy that with all three types of standing wave within a room or space there is always a pressure maximum at the walls—something which seems to be contrary to the observation made by Tandy: “interestingly, the vibration got bigger until the blade was level with the desk (half way down the

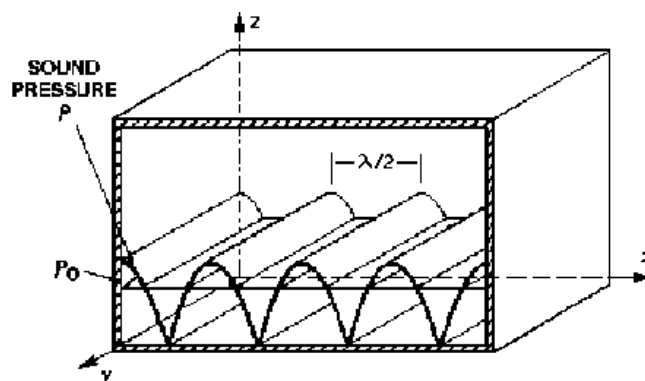

Figure 4. Axial room waves.

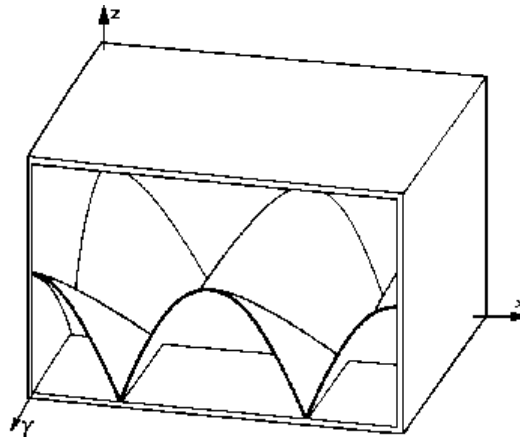

Figure 5. *Tangential room waves.*

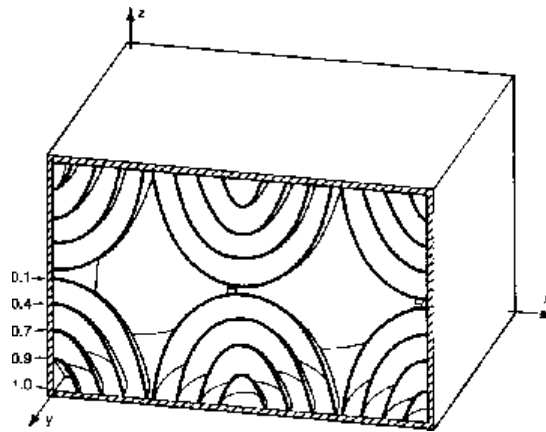

Figure 6. *Oblique room waves.*

room); after the desk it reduced in amplitude, stopping altogether at the far end of the lab.” (Tandy & Lawrence, 1998). To calculate the frequencies of the axial, oblique and tangential modes, the following formula may be used:–

$$f = \frac{c}{2} \sqrt{\left(\frac{n_x}{L}\right)^2 + \left(\frac{n_y}{B}\right)^2 + \left(\frac{n_z}{H}\right)^2}$$

- f = Frequency of the standing wave in Hz
- c = Speed of sound (1139ft/sec. at 20°C)
- $n_x$  = Order of the standing wave for room length
- $n_y$  = Order of the standing wave for room width
- $n_z$  = Order of the standing wave for room height
- L, B, H = Length, width, and height of the room

Using the above formula and assuming the stated length of 30ft and estimating a reasonable width of 12ft and a height of 10ft we are presented with

a range of fundamental (first order) low-frequency standing waves present inside the lab room:–

18.8Hz (x axial wave)	50.7Hz (x-y tangential wave)	75.9Hz (x-y-z oblique wave)
47.1Hz (y axial wave)	59.6Hz (x-z tangential wave)	
56.5Hz (z axial wave)	73.5Hz (y-z tangential wave)	

As can be seen, there is not one standing wave existing inside the lab room but several, all of which to a greater or lesser degree may have affected the sword blade. Furthermore, the authors do not provide any information regarding the dimensions, i.e. the length, width and thickness, of the blade that was seen to be vibrating; thus it is impossible for us to calculate the resonant frequency of the blade itself and to know which standing wave(s) might therefore have been responsible for producing the observed vibrations within it.

Without extensive measurements being undertaken it will be practically impossible to predict all the various effects that acoustic vibrations might produce within structural systems (Broch, 1980). Tandy’s mathematical modelling of the standing wave within the lab also assumes that the source of the standing infrasound was a new fan fitted to the lab’s extraction system. Turning off the fan caused the sword blade to cease vibrating and the untoward experiences also ceased, which might indicate that the fan was indeed the source of a standing wave. However, this could equally indicate that an infrasound standing wave of unknown frequency/ies had been formed by the interactions of the fan noise with an external infrasound source. We have seen that infrasound has been shown to be capable of travelling large distances without significant attenuation, and as no infrasound measurements were made within the lab, both with and without the fan, it is not possible to know which is the case here. Taking the above into consideration, it could be argued that the case for a 19Hz standing wave effect is not as strong as it first appeared. This is further borne out by the pilot study in Edinburgh and the concert applications of infrasound, neither of which produced the visual hallucinations or the apparitional experiences that Tandy suggested were caused by a 19Hz infrasound exposure.

*Is Infrasound Being Measured Properly by Paranormal Researchers?*

Tandy (2000) reports finding an infrasound standing wave at 19Hz with amplitude of 38dB in the haunted cellar. Unfortunately, he does not specify what weighting filter (if any) was applied to this measurement. As has already been described, the use of a filter weighting scale (i.e. A, B, C, or D) when obtaining infrasound measurements of the ambient levels of infrasound within the environment may result in the erroneous under-reporting of the actual levels present. Given the type of equipment used by Tandy (a Bruel & Kjaer Type 2209 sound-level meter), if one of the standard weighting filters was applied to the data, either the ‘C’ or more likely the ‘A’ weighting, its use could lead to a serious underestimate of the infrasound pressure levels. Broner (1978) describes a case in a London home where infrasound which was causing annoyance to the wife but not the husband was measured to be only 32dB using ‘A’ weighting, but the SPL was actually measured at 63dB.

In September 2006, immediately before its closure, the author was able to undertake a series of infrasound measurements at the haunted cellar in Coventry, using ARID to repeat the experiment carried out by Tandy. Replicating Tandy's placement, the microphone was positioned in the centre of the cellar with infrasound measurements being made automatically at one-minute intervals in the empty cellar. These previously unpublished measurements did not support his claim of finding a 19Hz standing wave within the cellar, although infrasound was found to be present at a broad range of frequencies, exceeding 30dBS between 20Hz and 2Hz, with a peak at 44dBS at 5.7Hz.

It is difficult to make any further comparisons between the two infrasound surveys because of the variability of location of infrasound production on account of changes in the ambient sources; plus not knowing the filter weighting that Tandy used for his measurements, and the lack of proper calibration for the prototype ARID system at that time.

Tandy (2000) acknowledges that his measured value of 38dB within the cellar is substantially lower than those previously reported to have effects on people, but suggests that as the effects are rather less spectacular this may simply be the result of the lower amplitudes found. Braithwaite and Townsend (2006) also make the point that there are no published studies that have found any implications for cognition or experience of infrasound as weak as this. In fact, as already noted, the actual levels of infrasound present may have been substantially higher and therefore much closer to those demonstrated to have produced effects. This difference in measuring and quoting infrasound levels between field and laboratory studies may also provide an explanation for the results of other experiments where low-amplitude infrasound has been suggested to have effects (Brown, 1973; Green & Dunn, 1968).

Another difficulty in determining infrasound amounts from field measurements is the sampling period used. In his experiments within the haunted cellar Tandy (2000) reports using a sample time of just 20 seconds. Although we are informed that the measurements were repeated a number of times it is not made clear whether the resultant data came from one sample period or were the average of a number. A short sampling period of 20 seconds will inevitably involve the overall measured infrasound values being affected by transient high-energy events; for example, a passing bus or other vehicle or the slamming of a nearby door. Weather effects and weather interactions with the structure of the location being measured such as a wind gust might also generate infrasound during the sampling period. Using a longer sampling period would permit such transients to be taken in account and would allow a more realistic assessment of the true ambient infrasound levels to be made. The author's own measurements at the haunted cellar showed that there were indeed short-duration infrasound events caused by passing vehicles, including buses and delivery vehicles. It was also discovered that the presence of people within the cellar contributed significantly to the production of infrasound. Increases in the measured infrasound levels of between approximately 15 and 30dBS were recorded as members of the experimental team moved and walked about within the cellar. Tandy records that he vacated the cellar prior to his measurements being carried out. However, the original incidents took the form of visitors' personal anomalous experiences during tours of the historic



cellar, suggesting that vacating the cellar may not have provided an accurate reflection of the prevailing conditions at the time of the original incident(s).

Following the death of Tandy there had been little effective research into the possible involvement of infrasound in the production of paranormal experiences. However, since 2006, the author has undertaken a series of broadband infrasound measurements using ARID at a number of locations around the UK, and has conducted a number of experiments to study the link between infrasound exposure and reports of anomalous and paranormal experiences. A pilot study was carried out at a former shipyard on Merseyside during 2006 (Para.Science, 2007). The location had a reputation among staff of being haunted, and paranormal investigators reported physiological and psychological effects that might be associated with infrasound exposure. Results of the pilot study suggested a strong link between high ambient levels of infrasound (up to 80dBS) at frequencies between 7Hz and 15Hz and reports of anomalous experiences in the percipients. The source of the powerful ambient infrasound was traced to the engines and associated equipment of ships berthed in an adjacent dock. A psychic medium also reported changes within the 'psychic energies' at the location that closely corresponded to the objectively measured regions of high levels of ambient man-made infrasound.

#### *Infrasound Exposure Pilot Study*

During 2007, the author was part of a team that conducted a pilot study at the Real Mary Kings Close tourist attraction in Edinburgh as part of their annual *GhostFest* event. A controlled level of infrasound was produced using the author-designed infrasound generator, Acoustic Research Infrasound Array (ARIA). Throughout the study period ambient levels of infrasound were measured using ARID2. Hourly tour groups to Mary Kings Close were unknowingly subjected to either only the ambient infrasound that is normally present or the ambient infrasound plus experimenter-produced high-level (>100dBS) infrasound at a frequency of 18.9Hz. The route of the tours and the commentary of the tour guides were observed and remained consistent for all the tour groups. The physical conditions such as lighting and temperature within the location were constant throughout the period of the study. Upon completion of the tour the subjective anomalous experiences of 439 individuals were surveyed. The results obtained strongly indicated that infrasound exposure played a significant role in the production of subjective paranormal experiences for around one-third of the total survey. However, the study failed to demonstrate any of the visual disturbances and resulting apparitional experiences that Tandy had suggested would be created by exposure to the frequency range around 18Hz (Para.Science, 2008).

ARIA has also been used in two public performances (Silent Sound, 2006, 2010) in which a frequency of 18.9Hz was produced at an SPL exceeding 90dBS. Anecdotal accounts from participants and audience members did indicate a significant number of psycho-physiological effects, such as feeling ill at ease, anxiousness and physical discomfort, being experienced when ARIA was in use. For example, during the first performance with ARIA at the 2006 Silent Sound performance held in Liverpool St George's Hall a number of the musicians within the auditorium reported feeling unwell and nauseous and

were unable to play their instruments, ultimately abandoning the room during a rehearsal session as the output level of ARIA was being set. During this set-up test infrasound levels of more than 90dBS were measured at 10m from the infrasound generator. Following the ARIA test, the author also discovered that on the ground level, three floors below the auditorium, a security guard had also reported feeling suddenly unwell and had left the building. None of these unfortunate side-effects of the infrasound exposure lasted more than a few minutes and they ceased once the infrasound generator was switched off. For the actual performance infrasound levels of 60dBS were used (measured at 10m from the infrasound generator). Following the performance audience members and several musicians anecdotally reported unexpected sensations, including vertigo, pressure in the ears and the sensation of 'having something pressed tightly over the head'. Similar experiences were reported during the 2010 concert held in Middlesbrough. At neither performance were any visual or apparitional experiences reported.

#### *The 'Haunt' Project*

Tandy's hypothesis that infrasound may be responsible for inducing anomalous sensations was tested by French, Haque, Bunton-Stasyshyn and Davis (2009) in the 'Haunt' Project, which used infrasound to investigate the possibility of creating an artificially 'haunted' room. Specifically, they investigated whether exposure to infrasound, complex electromagnetic fields, or both in combination, would lead to an increased reporting of anomalous sensations in participants, compared with a baseline condition. The room was a circular chamber of wood, fabric and canvas built inside an empty room approximately 4m × 4m (based upon the plans of the experimental area). A pair of electromagnetic coils were hidden outside the chamber along with a single infrasound speaker positioned outside the chamber in a corner of the main room. The infrasound was generated by "combining two sine waves at 18.9Hz and 22.3Hz" output via a "purpose-built cabinet" These frequencies were chosen to be representative of the infrasound recorded by Tandy in the Coventry cellar. Participants each spent 50 minutes in the chamber and recorded on a floor plan a brief description of any anomalous sensations that they experienced, also noting their position within the chamber and the time the sensation was experienced. The participants were randomly allocated to experimental conditions according to the presence or absence of infrasound and electromagnetic field.

Many of the participants reported having anomalous sensations, a number of which have previously been linked to infrasound exposure: dizzy or odd feelings (79.7%), spinning around (49.4%), tingling sensations (32.9%) and pleasant vibrations through their bodies (31.6%). Other sensations linked to infrasound exposure were also reported, including the sense of presence (22.8%), terror (8.9%) and sexual arousal (5.1%). Sensations that may be associated to infrasound were additionally reported such as hearing a 'ticking sound' (25.3%). This may have been the result of changes within the air pressure caused by the infrasound acting on the ear or acting upon some structural component within the room or chamber and causing resonance. Sensations were reported that have no association with infrasound exposure, such as the

participants feeling they were somewhere else (32.9%), feeling detached from their bodies (22.8%), sadness (11.4%) and odd smells (10.1%).

The researchers reported that they had failed to find any support for a link between the presence of infrasound and the experiencing of anomalous sensations, suggesting that “the case for infrasound inducing haunt-type experiences now appears to be extremely weak”. However, this experiment fails to address properly a number of issues relating to the physics of infrasound, so this conclusion seems unsound. In order to establish undetectable levels of infrasound within the chamber a series of pilot trials were carried out, participants being asked to indicate when they became aware of the infrasound stimulus at a range of frequencies: 15Hz, 17Hz, 19Hz, 21Hz, 23Hz and 25Hz. During this pilot it was determined that “no participant was able to perceive infrasound at a level below 75dB”. It is not stated what equipment or method was used to obtain these sound-level data or what (if any) weighting was applied to the measurements. As previously discussed, it is perfectly possible that significantly higher amplitudes of low-frequency ambient sound and infrasound may have been present throughout the entire experiment without being measured by the experimenters. Moreover, the use of two combined sine waves (18.9Hz and 22.3Hz) will result in the production of secondary frequencies as a result of inter-modulation between the two primary signals. These secondary tones (harmonics) are equal to the sum and difference of the two primary frequencies, i.e.  $f_1 \pm f_2$  (3.4Hz and 41.2Hz). Other harmonic frequencies well within the region of normal human hearing might also be expected to be present. The experiment also did not consider interactions of the infrasound within the room itself caused by reflected and refracted sound waves bouncing off the walls, floor and ceiling and the possible effects upon the participants as they walked through what might have been large variations in both the sound frequencies presented, although interestingly the experimenters noted in relation to the electromagnetic field that “the nature of the field itself can vary infinitely and the participants’ movements through the field will add an extra level of complexity to the field as experienced”. Measurements that were made are stated to be “50dB with all the equipment turned off, 65dB with the air-conditioning switched on and 75dB” when the infrasound was switched on. No information was provided about the sound-measuring equipment that was used or any indication whether any frequency weighting was applied to the measurements. Without this crucial information about the ambient infrasound levels present, the experimenters’ argument against the role of infrasound as a causal factor in the production of anomalous sensations reported by the participants must be questioned.

#### *Should Paranormal Researchers be Interested in Infrasound at all?*

The work by Tandy and Lawrence (1998) and Tandy (2000) remains the only real basis for the assumption of an infrasonic involvement in personal experiences at haunt locations. Inevitably, such primary studies are flawed because there is little or no preceding data for the authors to make use of when developing their arguments. However, there are clear similarities between the reported experiences and sensations of those people who have experienced infrasound and those reporting paranormal experiences and sensations. The

author's preliminary studies in the former shipyard and in Mary Kings Close, together with the anecdotal reports from the infrasound concerts, also strongly suggest that infrasound is a component in the production or enhancing of reported paranormal experiences. The suggestion of a link between infrasound and reported paranormal experiences was also tested in 2003 in a series of 'Soundless Music' concerts that took place in Liverpool and London (Arenda & Thackara, 2003). Questionnaires handed to the audience elicited a range of reported experiences. Many unusual experiences were reported during the concerts, ranging from the emotional (e.g. 'sense of sorrow'), 'brief moment of anxiety' and 'excited' to the physiological (e.g. 'increased heart-rate'), 'headache', 'tingling in neck and shoulders', 'nausea', 'sense of coldness' (Infrasonic, 2003). The 'Soundless Music' concerts used an infrasound frequency of 17 Hz but from their own spectral measurements of the infrasound we can readily see that infrasound is present at all frequencies below 20 Hz at considerable intensity.

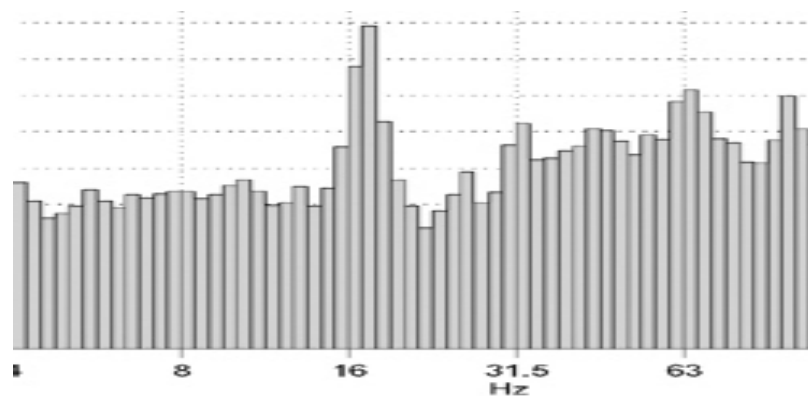

Figure 7. Spectral plot from Silent Sound concert (Infrasonic, 2003).

Susceptibility to psycho-physiological effects of infrasound exposure seems to be linked to both exposure duration and overall sound-pressure level (Kitamura & Yamada, 2002). Prolonged exposure to low infrasound pressure levels has been suggested as a likely cause of adverse psycho-physiological effects (Benton, 1997). Although the limited research does not directly indicate it, it might be fair to assume that short-duration exposure to high infrasound pressure levels may cause similar effects. Existing research does indicate that exposure to high levels of low-frequency sound at concerts or in some industry explosions does cause aural pain and other physical effects; such effects may be temporary or permanent (Fearn, 1973).

A key problem lies with the lack of information about levels of ambient infrasound at haunt locations. Such studies that are available have been made either following noise complaints or for the establishment of safe exposure limits and thresholds within high noise environments. This lack of baseline data is a crucial problem for paranormal researchers seeking to test or develop the case for an infrasound involvement and must be addressed urgently if meaningful research is to continue. The ongoing survey also measures the infrasound at similar or co-located control (non-haunt) sites in order to ascertain whether there are any significant differences in the ambient infrasound

frequencies and amplitudes at haunt locations compared with the control sites. The survey also undertakes measurements of the ambient infrasound at a wide range of locations regardless of any paranormal association or reports, in order to establish a set of baseline ambient infrasound data to support future infrasound studies. The need for such baseline data was also highlighted by Braithwaite and Townsend (2006).

From the limited studies conducted to date and the knowledge that infrasound is produced by so many natural and man-made sources, it now seems highly likely that infrasound is just one of many factors that may lead to the reporting of anomalous or paranormal experiences by some individuals. A number of other possibilities are indicated:—

(i) Infrasound alone does not produce anomalous and paranormal experiences.

(ii) The frequency range around 18Hz does not produce the apparitional experiences as suggested by Tandy and Lawrence.

(iii) That infrasound presented at a range of frequencies is more likely to produce reports of anomalous and paranormal experiences than single-frequency infrasound.

(iv) That a rapid variation in the infrasound frequency and/or amplitude i.e. >1Hz per second or 3dB per second is more likely to contribute to the reporting of anomalous and paranormal experiences than infrasound that is constant or is slowly changing.

(v) That a small variation in the infrasound frequency and/or amplitude, i.e.  $\pm 2$ Hz or  $\pm 3$ dB, is more likely to contribute to the reporting of anomalous and paranormal experiences than greater variations.

A series of studies are under way or are being planned to test the indicated possibilities. Further developments of both ARID and ARIA are planned which will permit better measurements of the ambient infrasound to be made and to support further studies of infrasound exposure experiences.

#### REFERENCES

- Altmann, J. (1999) *Acoustic Weapons, A Perspective Assessment: Sources, Propagation and effects of Strong Sound*. Occasional Paper #22, Cornell University Peace Studies Program. New York.
- Anon. (1977a) Hounded by this nagging noise. *The Sunday Mirror* (26th June).
- Anon. (1977b) Hum—that mystery noise that drives sobbing wife out of the house. *The Sunday Mirror* (3rd July).
- Arenda, B. and Thackara, D. (2003) *Experiment: Conversations in Art and Science*. The Wellcome Trust.
- Backteman, O., Kohler, J. and Sjoberg, L. (1983) Infrasound: tutorial review, Part 2. *Journal of Low-Frequency Noise and Vibration* 2, 176–210.
- Berglund, B., Hassmen, P. and Job, R. F. (1996) Sources and effects of low-frequency noise. *Journal of the Acoustical Society of America* 99 (5), 2985–3002.
- Blazier, W. E. (1981) Revised noise criteria for application in the acoustical design and rating of HVAC systems. *Journal of Noise Control Engineering* 16, 64–73.

- Braithwaite, J. and Townsend, M. (2006) Good vibrations: the case for a specific effect of infrasound in instances of anomalous experience has yet to be empirically demonstrated. *JSPR* 70, 211–224.
- Broner, N. (1978) The effects of low-frequency noise on people. *Journal of Sound Vibration* 58, 483–500.
- Brown. (1973) New worries about unheard sound. *New Scientist*, 414 (8th November).
- Brüel and Kjaer (1982) Sound Intensity. Part 1: Theory. *Technical Review* 1982 (3).
- Bruel, P. V. and Olesen, H. P. (1973) Infrasonic measurements. *Paper Presented at the Inter-Noise Conference, Copenhagen, 1973*.
- Bullen, R. B., Hede, A. J. and Job, R. F. S. (1991) Community reaction to noise from an artillery range. *Noise Control Engineering Journal* 37, 115–128.
- Challis, L. A. (1978) Low-frequency noise problems from gas turbine stations. *Proceedings Internoise* 78, 475–480.
- Chen, Y. H. Q. and Hanmin, S. (2004) An investigation on the physiological and psychological effects of infrasound on persons. *Journal of Low-Frequency Noise Vibration and Active Control* 23 (1), 71–76.
- Corso, J. F. (1958) Absolute thresholds for tones of low frequency. *American Journal of Psychology* 71, 367–374.
- DIN: 4560 (1997) *Measurement and Evaluation of Low-Frequency Environmental Noise*.
- Fearn, R. (1973) Pop music and hearing damage. *Journal of Sound and Vibration* 29, 396–397.
- Feynman, R. P., Leighton, R. and Sands, M. (1963) *The Feynman Lectures on Physics, Vol.1*, ch.49. New York: Addison-Wesley.
- Fielding, Y. and O’Keeffe, C. (2006) *Ghost Hunters: A Guide to Investigating the Paranormal*. London: Hodder & Stoughton.
- Fields, J. M. (2001) *An Updated Catalog of 521 Social Surveys of Resident’s Reaction to Environmental Noise*. NASA Report, NASA/CR-2001-211257.
- Fodor, N. and Lodge, O. (1933) *Encyclopedia of Psychic Science*. London: Arthurs Press.
- French, C. C., Haque, U., Bunton-Stasyshyn, R. and Davis, R. (2009) The ‘Haunt’ Project: an attempt to build a ‘haunted’ room by manipulating complex electromagnetic fields and infrasound. *Cortex* 45 (5), 619–629.
- Frost, G. P. (1987) An investigation into the microstructure of the auditory threshold and of the loudness function in the near threshold region. *Journal of Low-Frequency Noise Vibration* 6, 34–39.
- Gamberale, F., Goldstein, M., Kjellberg, A., Liszka, L., and Lofstedt, P. (1982) *Perceived Loudness and Annoyance of Low-Frequency Noise*. Stockholm: Arbete & Halsä.
- Garces, M., Hegarty, M. and Schwartz, S. (1998) Magma acoustics and the time-varying melt properties at Arenal volcano, Costa Rica. *Geophysical Research Letters* 25 (13), 2239–2296.
- Gauld, A. and Cornell, A. D. (1979) *Poltergeists*. London: Routledge & Kegan Paul.
- Gavreau, V. (1966) Infra Sons: Générateurs, Détecteurs, Propriétés physiques, Effets biologiques. *Acustica* 17 (1), 1–10.
- Gavreau V. (1968) Infrasound. *Science Journal* 4, 33–37.
- Goldstein, M. (1994) *Low-Frequency Components in Complex Noise and their Perceived Loudness and Annoyance*. Unpublished PhD dissertation, Stockholm University.
- Gossard, E. E. and Hooke, W. H. (1975) *Waves in the Atmosphere*. Elsevier Science Publishers, USA.
- Green, J. F. and Dunn, F. (1968) Correlation of naturally occurring infrasonics and selected human behavior. *The Journal of the Acoustical Society of America* 44 (5), 1456–1457.
- Hansen, C. H. (2007) *The Effects of Low-Frequency Noise and Vibration on People*. Essex: Multi-Science Publishing.

- Harris, C. S., Sommer, H. C. and Johnson, D. L. (1976) Review of the effects of infrasound on man. *Aviation and Space Environmental Medicine* 47, 582–586.
- Hegarty, M., Kim, W. and Martysevich, P. (1999) Characteristics of infrasound produced by large mining explosions in Kazakstan. *Proceedings of the 21st Annual Seismic Research Symposium: Technologies for Monitoring the Comprehensive Nuclear Test-Ban Treaty, Las Vegas, USA, 1999*.
- Infrasonic. (2003) Infrasonic—Summary of results 31st May, 2003, Purcell Room, London. <http://www.spacedog.biz/extras/Infrasonic/infrasonicResults.htm> [Accessed 1st December 2011]
- Jerger, J., Alford, B., Coats, A. and French, B. (1966) Effects of very low frequency tones on auditory thresholds. *Journal of Speech and Hearing Research* 9, 150–160.
- Job, R. F. S. (1993) Psychological factors of community reaction to noise. In Vallet, M. (ed.) *Noise as a Public Health Problem, Vol. 3*, 48–70. France: INRETS.
- Karpova, N. I., Alekseev, S. V., Erohkin, V., Kayskina, E. N. and Reutov, R. P. (1970) Early response of the organism to low-frequency acoustic oscillations. *Noise and Vibration Bulletin* 11, 100–103.
- Kawano, A., Yamaguchi, H. and Funasaka, S. (1991) Effects of infrasound on humans: a questionnaire survey of 145 drivers of long-distance transport trucks. *Practical Ortolology* 84, 1324–1325.
- Kitamura, T. and Yamada, S. (2002) Psychological analysis of sufferers of low-frequency noise and relation between brain structure and psychological response. *Proceedings of the 10th International Meeting on Low-Frequency Noise and Vibration and its Control, York, UK, 2002*.
- Leventhall, G., Pelmear, P. and Benton, S. (2003) *A Review of Published Research on Low-Frequency Noise and its Effects, 7*. London: DEFRA Publications.
- Lidstrom, I. M. (1978) The effects of infrasound on humans. *Investigation Report (UMEA)* 33, 1–42.
- Lisker, L. and Abramson, A. (1970) The voicing dimension: some experiments in comparative phonetics. *Proceedings of the 6th International Congress of Phonetic Sciences, 1967*. Prague: Academia.
- Lydolf, M. and Moller, H. (1997) New measurements of the threshold of hearing and equal loudness contours at low frequencies. *Proceedings of the 8th International Meeting on Low-Frequency Noise and Vibration, Gothenburg, 1997*, 76–84.
- Masterton, R. B. (1992) Role of the central auditory system in hearing: the new direction. *Trends in Neurosciences* 15, 280–285.
- McKisic, J. M. (1997) Infrasound and the infrasonic monitoring of atmospheric nuclear explosions. *USAF Technical report, PL-TR-97-2123, Phillips Laboratory, Hanscom AFB*. USA: US Dept of Defense.
- Mihan House, S. (2005) *Infrasonic Wave Propagation Over Near Regional and Tele-Infrasonic Distances*. Ann Arbor: ProQuest Information & Learning.
- Moller, H. (1984) Physiological and psychological effects of infrasound on humans. *Journal of Low-Frequency Noise Vibration* 3 (1), 1–17.
- Moller, H. and Andresen, J. (1984) Loudness of pure tones at low and infrasonic frequencies. *Journal of Low-Frequency Noise Vibration* 3 (1), 78–87.
- Nishimura, K., Kudoda, M. and Yoshida, Y. (1987) The pituitary adenocortical response in rats and human subjects exposed to infrasound. *Journal of Low-Frequency Noise Vibration* 6, 18–28.
- Ostdiek, V. and Bord, D. (2000) *Inquiry into Physics*. USA: Brooks/Cole.
- Para.Science (2007) Cammell Laird Shipyard, Birkenhead. <http://www.parascience.org.UK/investigations/laird/laird.htm> [accessed 1st December, 2011]
- Para.Science (2008) Mary Kings Ghost Fest, 2007—Preliminary results. <http://www.parascience.org.uk/mkgfr.htm> [accessed 1st December 2011]

- Parsons, S. and O'Keeffe, C. (2008) Acoustic Research Infrasound Detector. *JSPR* 72, 51–57.
- Persinger, M. A. (1974) *The Paranormal: Part II. Mechanisms and Models*. New York: MSS Information Corporation.
- Pichon, A. L., Guilbert, J., Vega, A., Garces, M. and Brachet, N. (2002) Ground-coupled air waves and diffracted infrasound from the Arequipa earthquake of June 23, 2001. *Geophysical Research Letters* 29 (18), 331–334.
- Price, H. (1974) *Confessions of a Ghost Hunter (Causeway Edition)*. New York: Causeway Books.
- Schomer, P. D. (1981) Community reaction to impulse noise: initial Army survey. *US Army Construction Engineering Research Laboratory, Technical Report N-100*. Champaign IL.
- Silent Sound. (2006 and 2010) [http://www.silentsound.info/sound\\_silentsound.html](http://www.silentsound.info/sound_silentsound.html) [accessed 1st May 2010]
- Stephens, R. W. B. (1969) Infrasonics. *Ultrasonics (January)*, 30–35.
- Stevens, S. S. (1975) *Psychophysics: Introduction to its Perceptual, Neural and Social Prospects*. New York: Wiley.
- Stubbs, C. (2005) Tactical infrasound. *JASON, JSR-03-520*. Virginia: The MITRE Corporation.
- StudioSixDigital <http://www.studiosixdigital.com> [www.apple.com/itunes/](http://www.apple.com/itunes/)
- Svidovyl, V. I. and Kuklina, O. I. (1985) State of the 3-hemolymph circulatory bed of the conjunctiva as affected by infrasound. *Noise and Vibration Bulletin*, 153–154.
- Talbot-Smith, M. (1994) *Audio Recording and Reproduction: Practical Measures for Audio Enthusiasts*. London: Newnes.
- Tandy, V. (2000) Something in the cellar. *JSPR* 64, 129–140.
- Tandy, V. (2002) A litmus test for infrasound. *JSPR* 66, 167–174.
- Tandy, V. and Lawrence, T. R. (1998) The ghost in the machine. *JSPR* 62, 360–364.
- Tempest, W. (1971) Noise makes drivers drunk. *The Observer (28th November)*.
- Tempest, W. (1976) *Infrasound and Low-Frequency Vibration*. London: Academic Press.
- Usher, N. (1977) Pitch discrimination at low frequencies. *Acoustics Letters* 1, 36–37.
- von Gierke, H. E. and Parker D. E. (1976) Infrasound. In Keidel, W. D. and Neff, W. D. (eds.) *The Handbook of Sensory Physiology Vol. 3*, 585–624. Berlin: Springer-Verlag.
- von Gierke, H. E. and Nixon, C. W. (1976) Effects of intense infrasound on man. In Tempest, W. (ed.) *Infrasound and Low-Frequency Vibration*, 115–150. London: Academic Press.
- Watanabe, T. and Moller, H. (1990) Low-frequency hearing thresholds in pressure field and free field. *Journal of Low-Frequency Noise Vibration* 9, 106–115.
- Watson, L. (1973) *Supernature: The Natural History of the Supernatural*, 91–96. London: Hodder & Stoughton.
- Westin, J. B. (1975) Infrasound: a short review of effects on man. *Aviation Space Environmental Medicine* 46, 1135–1140.
- Yamada, S. (1980) Hearing of low-frequency sound and influence on the body. *Proceedings of the Conference on Low-Frequency Noise and Hearing, Aalborg, Denmark*, 95–102.
- Yasunao, M., Yukio, T., Setsuo, M., Hiroki, Y., Kazuhiro, Y. and Jishnu, K. S. (2009) *An Investigation of the Perception Thresholds of Band-Limited Low-Frequency Noises: Influence of Bandwidth*. Essex: Multi-Science Publishing.
- Yeowart, N. S., Bryan, M. and Tempest, W. (1967) The monaural MAP threshold of hearing at frequencies from 1.5 c/s to 100c/s. *Journal of Sound Vibrations* 6, 335–342.



## APPENDIX: A ROUGH AND READY TEST FOR AMBIENT INFRASOUND

Whilst techniques for measuring infrasound frequency and amplitude can be prohibitive both in terms of the equipment and cost, it is possible to undertake a simple test that will act as a rough guide to the presence or otherwise of significant levels of infrasound at a location. Tandy (2002) provides construction details for modifying a standard sound-level meter by the addition of a DIY low-pass filter network. This required a considerable expertise in electronics and integrated circuit construction techniques but did provide the user with a general indication of the amplitude of sound at frequencies below about 35Hz. There is, however, a much simpler method for quickly determining if low-frequency sound and infrasound are present at significant levels.

This simple method exploits the filter weighting already built into most sound-level meters. Suitable meters can be readily obtained from a number of sources including online retailers for less than £25. The method can even be employed by use of a sound-level meter App for the iPhone (3GS, 4, 4S), Ipad 2 and Ipod Touch (4th Gen.) such as 'SPL' (StudioSix-Digital), but with a reduced degree of accuracy. In order to carry out this simple test the sound-level meter must have both 'A' and 'C' weighting filters. Two consecutive measurements of the ambient SPL are taken: the first measurement is made using the 'A' filter, noting the SPL value; a second measurement using the 'C' filter is carried out, again noting the SPL value. If the SPL value of 'C' is greater than 'A' this indicates that there are increased levels of low-frequency sound present. The greater the difference between the 'C' value and the 'A' value, the higher the level of low-frequency sound at the measurement location. If the SPL value of 'C' is significantly higher than 'A', i.e. 10dBS or more, then it is likely that appreciable levels of infrasound are likely to be present. The technique exploits the difference in weighting between the 'A' and 'C' filters in the low-frequency sound region (Figure 8)

Although no direct information about either the frequency or amplitude is provided by this technique, it does permit the user to make a judgement about the level of low-frequency sound and infrasound. The overall accuracy of this technique can be improved by making a series of consecutive measurements over a period of time and/or taking measurements using the time average (Leq) function that some meters provide.

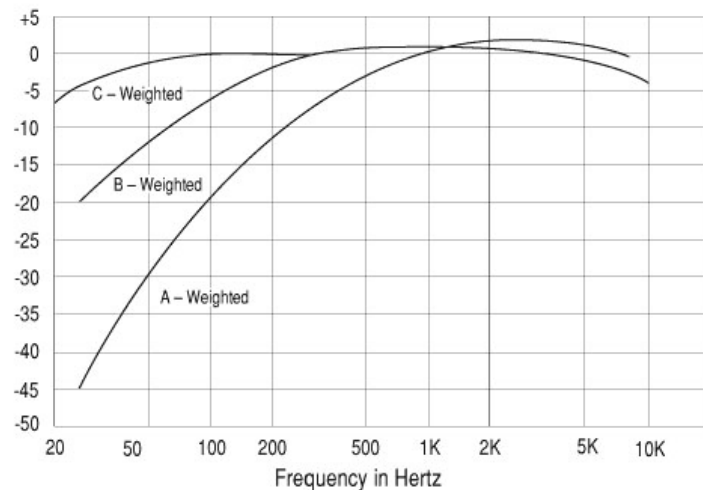

Figure 8. Comparison of sound-measurement weighting filters.